

## NIGHT BREAKER® LED VINTAGE

H4-LED + R2 ADAPTER | 12V  
64193DWNBVNT

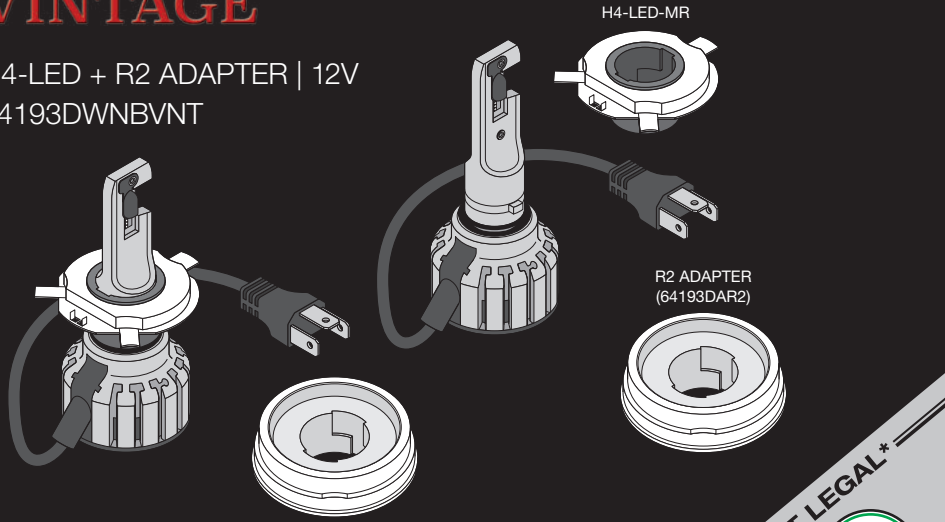

\* Applies only to vehicle models included on the current compatibility list and to light functions in the respective country. For specific terms, visit [www.osram.com/nb-led](http://www.osram.com/nb-led)<sup>1)</sup>

## NIGHT BREAKER® LED VINTAGE

H4-LED + R2 ADAPTER | 12V  
64193DWNBVNT



<http://www.osram.com/am-installation>

For questions regarding maintenance or technical problems, please contact OSRAM customer service via [automotive-service@osram.com](mailto:automotive-service@osram.com).<sup>1)</sup>



OSRAM Prosperity Co. Ltd  
Room 4007-4009 Office Tower  
Convention Plaza  
1 Harbour Road  
Wanchai, Hong Kong

[www.osram.com/am-guarantee](http://www.osram.com/am-guarantee)

C15140021  
G15141126  
05.05.25

OSRAM GmbH  
Nonnendammallee 44  
13629 Berlin, Germany  
[automotive-service@osram.com](mailto:automotive-service@osram.com)  
[www.osram.com](http://www.osram.com)

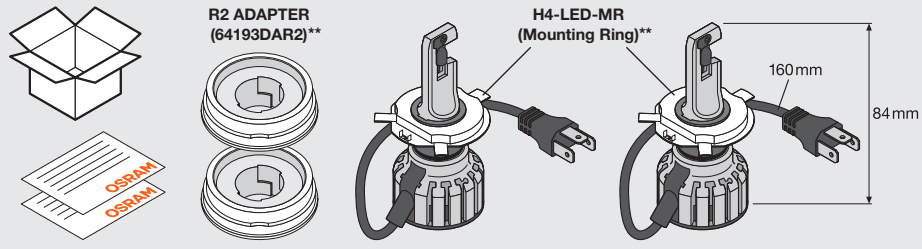

\*\* Depending on your vehicle model, please use H4-LED-MR (Mounting Rings) or R2 ADAPTER (64193DAR2) for the following installation options.<sup>2)</sup>

